

## T-5 Luminous Virtual Window Recessed Installation Instructions

### Recessed Installation

1. Frame the rough opening for LVW one half inch larger than actual outside dimensions of LVW extruded aluminum frame. See Figure 1.1 for typical framing details and Figure 1.2 for suggested framing additions.

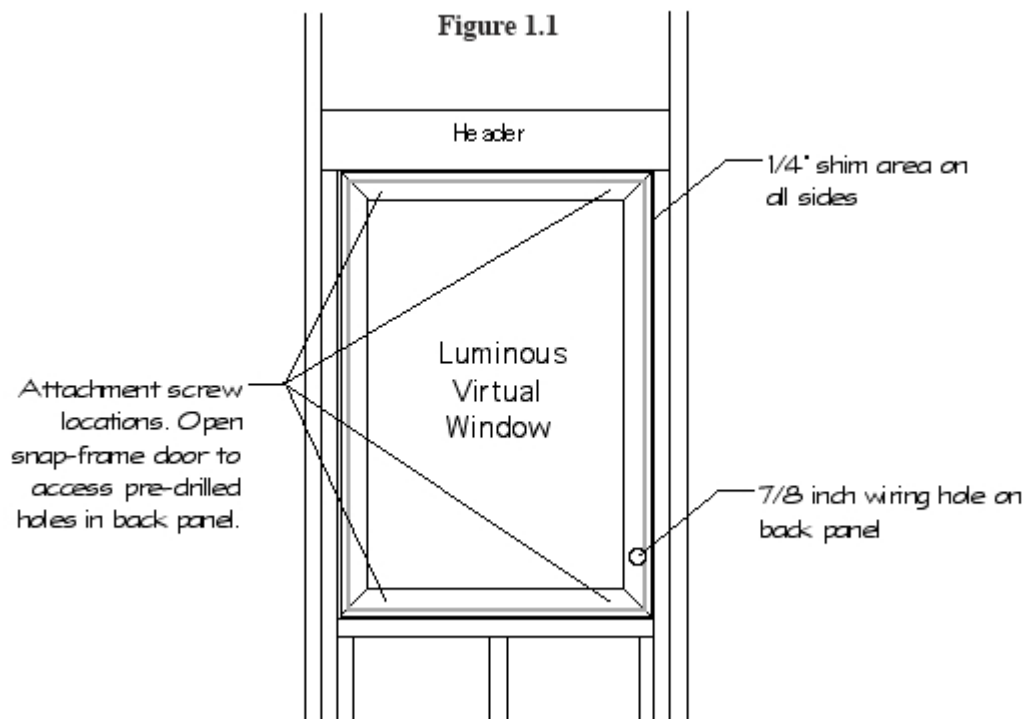

2. If your order included wood trim, remove it and set aside. The wood trim is held by ball-catch hardware. Using both hands, grasp the wood trim and pull directly outward.
3. Open front face snap-frame doors in order to remove the clear polycarbonate image cover and image beneath. The four snap-frame doors are hinged on the outside; to open, hook thumb in the v-groove on the inside edge of the door, gently slide the door toward the outside edge of the LVW, then flip up and out. Carefully remove cover and image, and store in a location where they will not be handled or damaged.
4. See Figure 1.2 for suggested framing additions for attaching LVW. Attach framing additions 1 11/16" back from finish wall surface. Use screws to facilitate possible

repositioning. **IMPORTANT:** Framing additions should be installed on two sides corresponding to predrilled installation holes only, and allowing for easy access to wiring. Location of 7/8" access hole may vary due to interior demands of lighting.

**Figure 1.2**

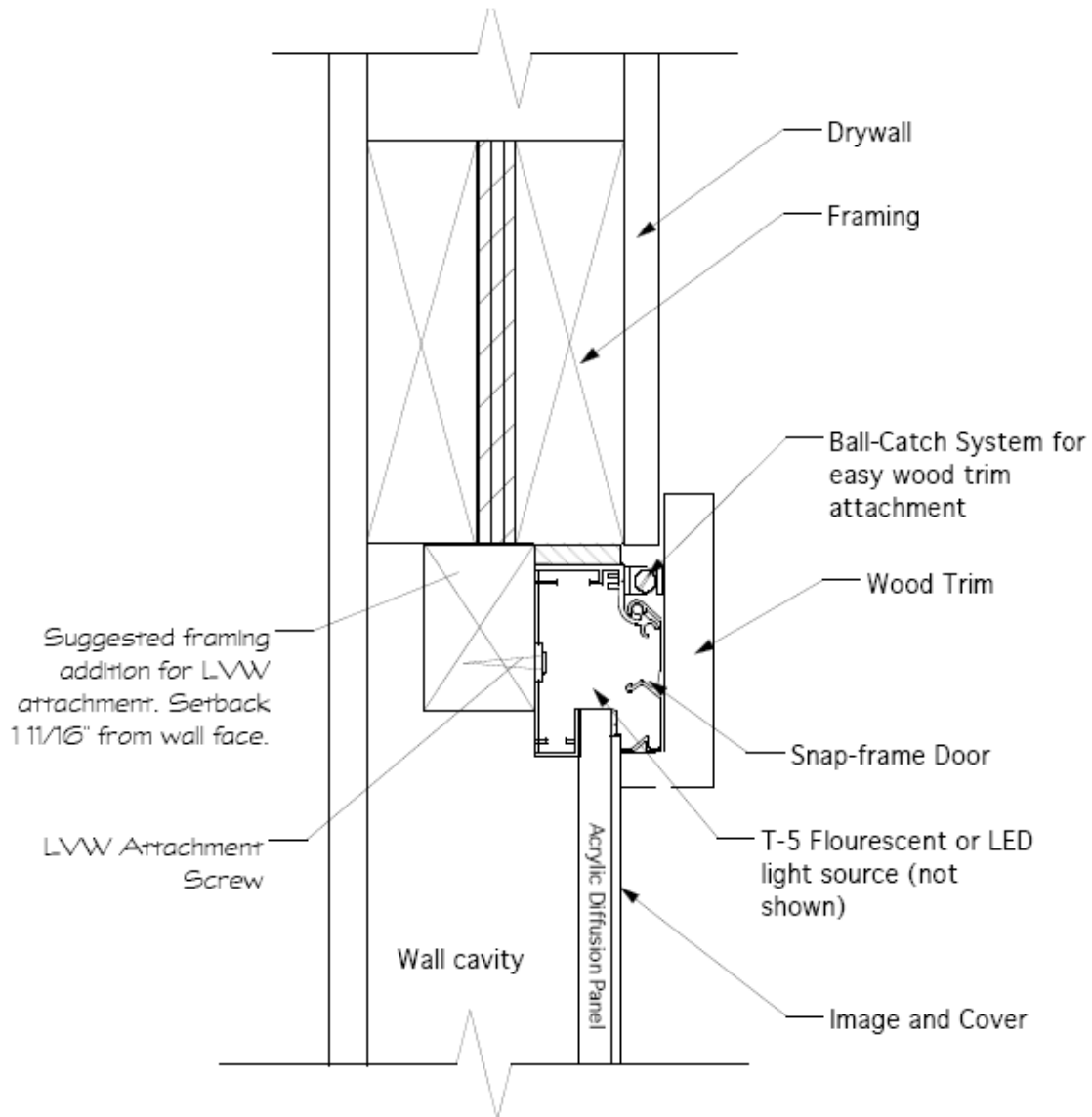

5. While inserting LVW into rough opening, pass wiring and box connector (enclosed) through predrilled 7/8" hole on the backside.

**Important:**

All wiring, insulation and other materials behind the LVW must not press against the white back panel.

**Pressure on the panel will create light "ghosts" in the image when lit.**

6. Holes for attaching LVW to framing are located on back panel.
7. Shim LVW to center and level within rough opening.
8. Before attaching LVW, hold firmly in place, and using straight-edge check to see that the most forward point of the wall surface is 1/16" back of the snap-frame door.
9. Attach LVW.
10. Make wiring connections. See Wiring, below.
11. Replace image and image cover:
  - a. Remove any protective coverings used during the installation of the LVW.
  - b. Clean the LVW to remove any dust from the installation as per cleaning instructions included.
  - c. Replace image and image cover. While holding image cover in place, close snap-frame door panels.
12. Install LVW wood trim:
  - a. Installing the LVW wood trim is easiest with two people.
  - b. Have one person lift the trim up so the eye screws in the back of the trim are at the same height as the safety cables on the LVW frame. Have the second person attach the quick links to the eyes and screw the gates closed.
  - c. Then lower the trim until the ball-catches line up and press the ball-catch locations.
  - d. To adjust holding strength of ball catches loosen or tighten adjustment screws on the two ends of the ball catches attached to the LVW frame.

## Wiring

For both vertical and horizontal installations

1. Open LVW snap-frame doors, remove image cover and image panel, and store in a safe location.
2. The LVW comes provided with 7/8" wiring hole on the backside.
3. Power is connected to three 18 AWG conductors via the 7/8" hole. Fasten 1/2" box connector through the hole and make the electrical connections inside the LVW frame.
4. After wiring is completed replace image, image cover and close the snap-frame door.

For technical support please call us toll free at 866-759-3228. We want your installation to go as smoothly as possible. Thank you for choosing The Sky Factory.